

### REFERENCE SYSTEM $\mu$ -PrisFix

High precision Mini-Clamping Reference System

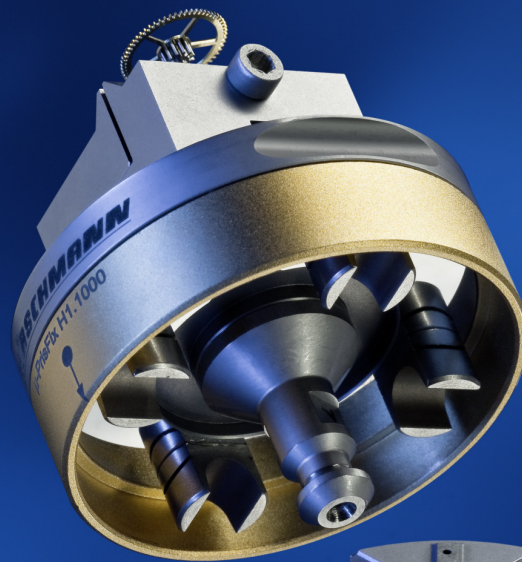

1  $\mu$ m changing accuracy  
from machine tool to machine tool

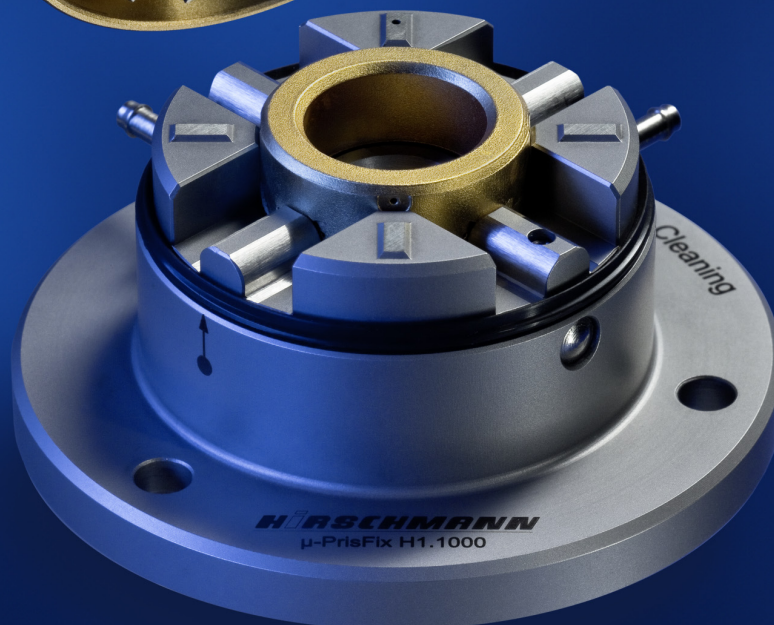

Made by HIRSCHMANN

Development from FMER-Project „MIKROPROKET“



Bundesministerium  
für Wirtschaft  
und Technologie



## Reference System $\mu$ -PrisFix

The completely rust-resistant Reference System  $\mu$ -PrisFix is a high precision mini clamping system which is used to manufacture small parts. The changing accuracy in the process chain (change over accuracy) of  $\leq 0,0010$  mm (0.00004") guarantees stable and repeatable production processes.

The patented System is used for metal cutting (milling, drilling, grinding) and EDM and laser machining of workpieces as well as in the measuring technology.

### Integrated functions

- The patented prism system with the stable integrated X-, Y-, und Z- references permit a high precision positioning.
- With HIRSCHMANN „Center-Clean“\* the centering prisms and the Z-supports are protected against dirt by a clustered air jet if there is no pallet in the clammer. When a pallet is clamped, the system is protected against dirt by a sealing ring.
- Pallet detection by measuring the pressure difference.
- Clamping control via piston position sensor.
- Integrated gripper interface in the pallet for automatic change
- The pallet can be equipped with the patented adjustable clamping element to be used as universal clamping element with maximum concentricity (see picture below).

### Features

- 1  $\mu$ m changing accuracy
- Total height with pallet only 42 mm (1.654")
- Completely sealed
- Integrated cleaning (HIRSCHMANN „CenterClean“\*)
- Integrated pallet detection and clamping check
- Clamping via spring pressure, opening via pneumatic pressure.
- Integrated gripper interface enables automatic change
- precise, safe, efficient

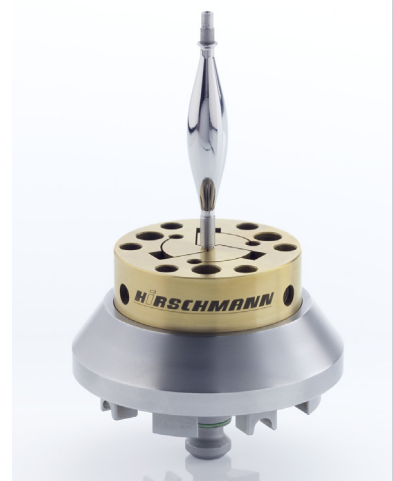

Pallet with Adjustable Clamping Element

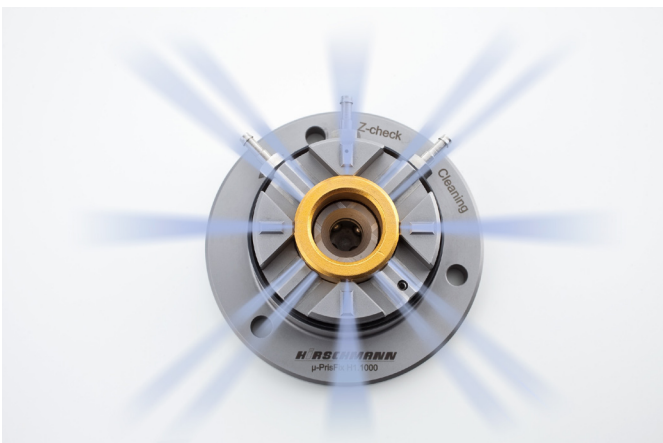

\*Protected against dirt with HIRSCHMANN „CenterClean“



Detail view HIRSCHMANN „CenterClean“

**μ-PrisFix Clamper and Pallet**

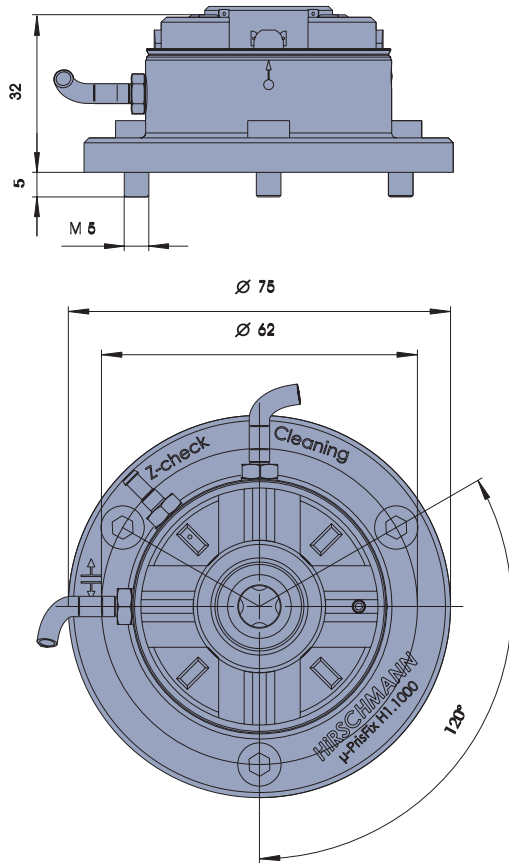

**μ-PrisFix Pneumatic Clamper H1.1000**

Completely made of rust-resistant materials. Clamping via spring pressure, opening via compressed air. Protected against dirt by a sealing ring and integrated cleaning ("CenterClean"). Pallet detection by measuring the pressure difference.

|                                       |                          |
|---------------------------------------|--------------------------|
| Repetitive accuracy                   | ≤ 0,0005 mm (≤ 0,00002") |
| Changing accuracy                     | ≤ 0,0010 mm (≤ 0,00004") |
| Clamper height (without/with pallet)  | 32/42 mm                 |
| Clamping force                        | 500 N                    |
| Pneumatic pressure (opening/cleaning) | 6 bar                    |

**μ-PrisFix Pneumatic Clamper H1.1000A**

Same as H.1.000 but with integrated sensor to check the position of the piston (clamping control).

(clamping control via piston position sensor and pallet detection by difference pressure measuring).

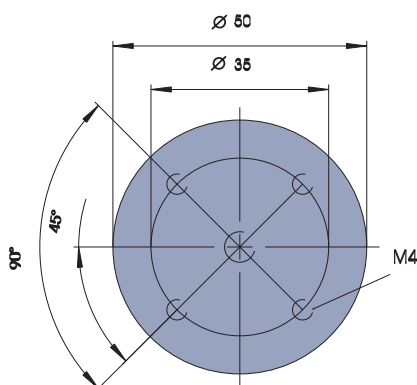
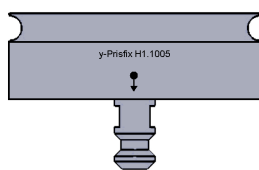

**μ-PrisFix Pallet H1.1005**

Completely rust-resistant. With four threaded holes M4/depth 5 mm for fastening of workpieces and fixtures, hardened and lapped.

Integrated gripper interface.

|                 |       |
|-----------------|-------|
| Pallet diameter | 50 mm |
|-----------------|-------|

Including clamping journal

# HIRSCHMANN

## REFERENCE SYSTEMS



Federal Ministry  
of Education  
and Research



## FMER-project: „MIKROPROKET“ Support code: 02PK2072

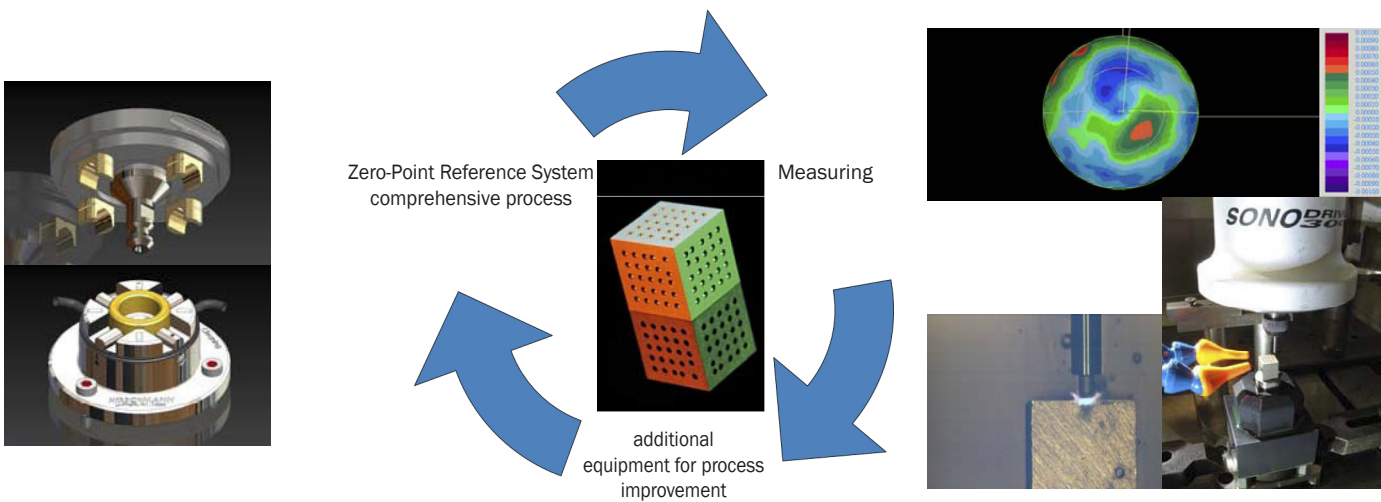

The common project has the aim to define a new procedural process chain for the production of  $\mu$ -structured components in consideration of the detected part geometry with integrative Zero-Point Reference Systems.

Stable and reproducible set production processes require mastered methods of production and equipment as well as available measurement concepts which are adapted to the production

process resp. integrated, sturdy and component flexible at the same time.

The requirement of a changing accuracy of  $<1 \mu\text{m}$  in the spatial coordinate system and an universality for the whole process chain while keeping the orientation by reference marks are tried to be realized. First testing results show the advantages of the micro production process chain.

HIGHTECH-STRATEGIE

Ideen zünden!