

## ROTARY INDEXING TABLES, A-AXES and ROTATING SPINDLES for Wire and Sinking EDM

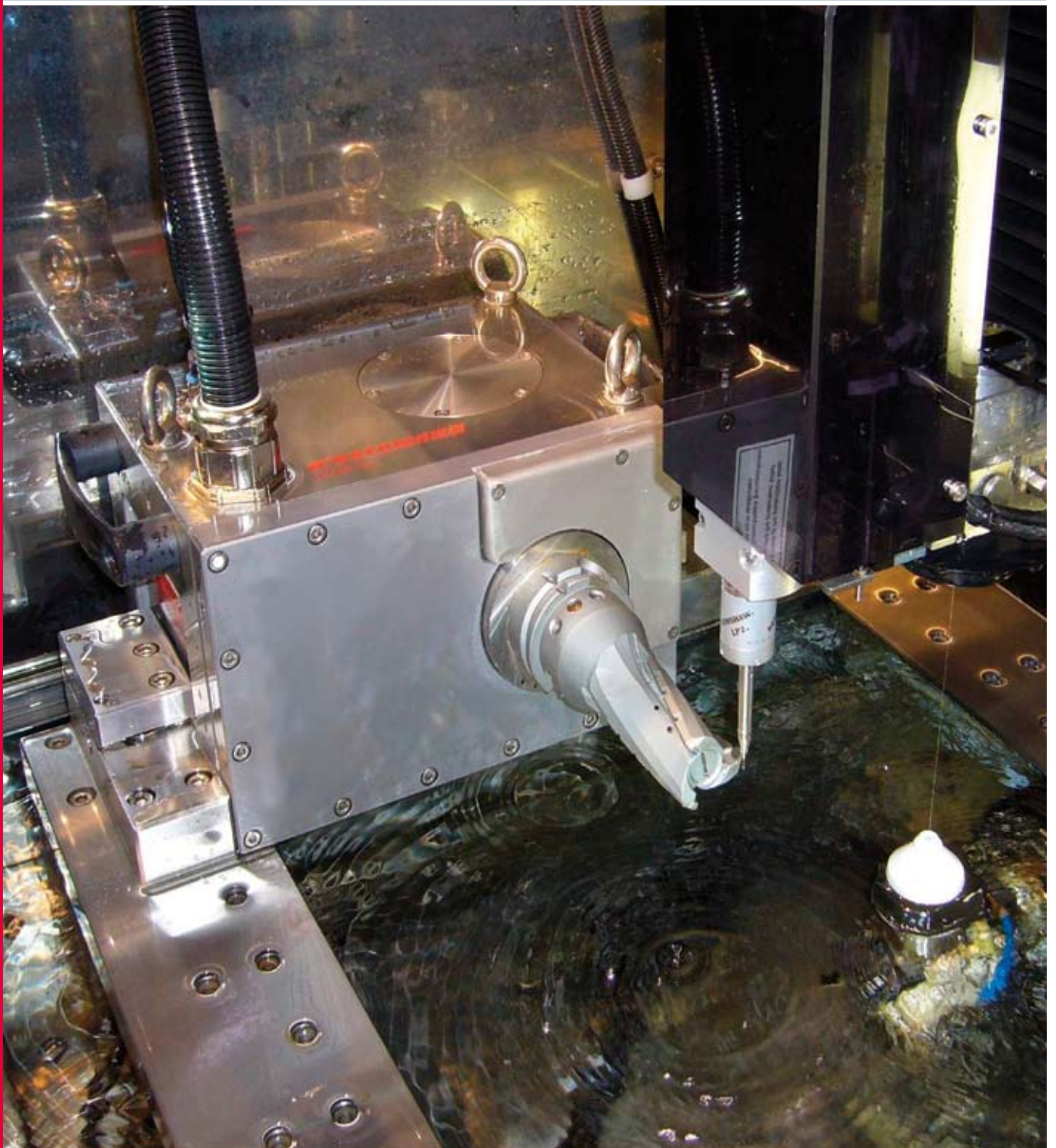

Pin point accuracy  
**Controlled dynamic power**  
Consistent performance.

- Positioning accuracy up to  $\pm 2,5$  sec.
- Repeat accuracy up to  $\pm 1$  sec.

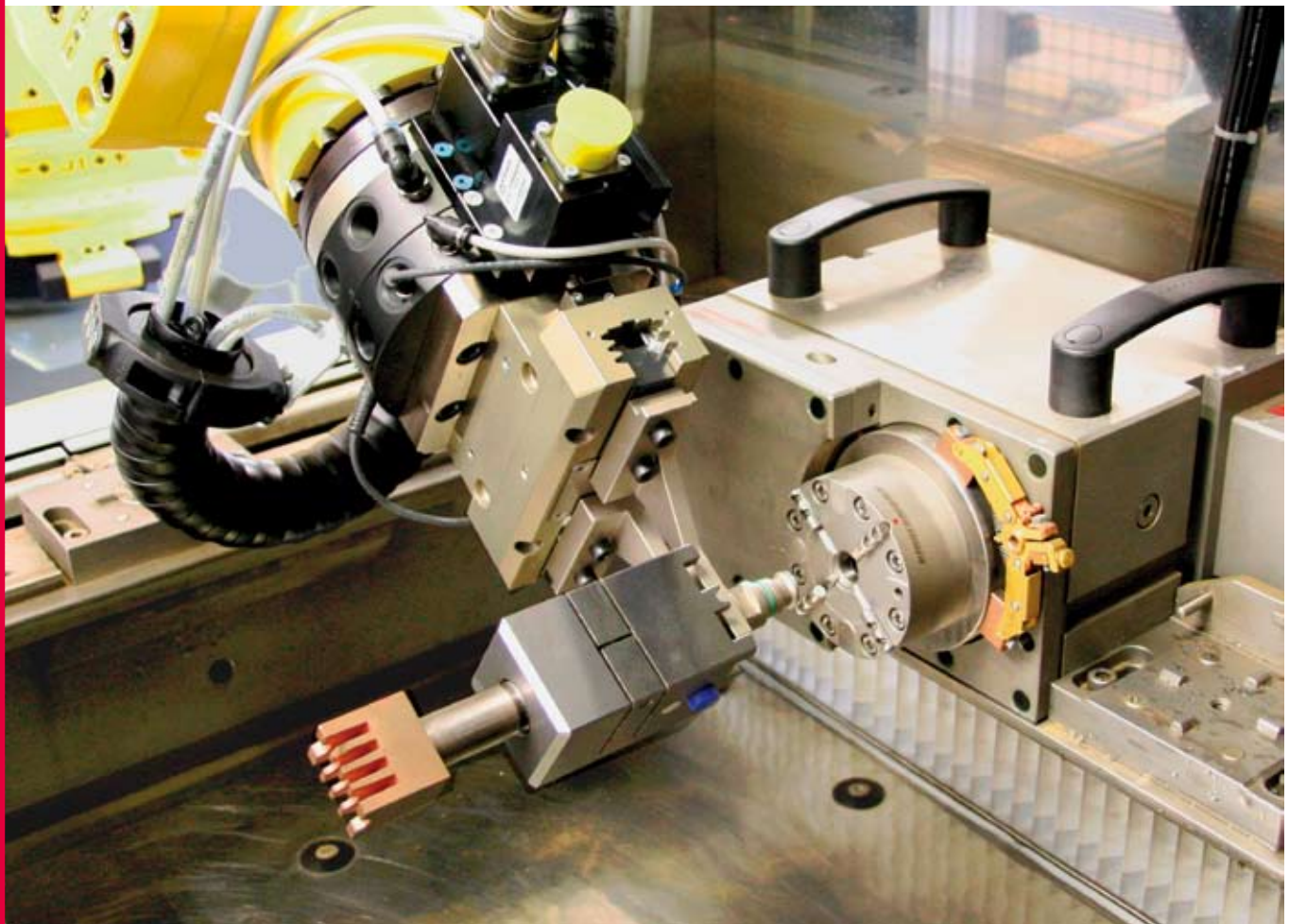

Automatic loading of workpieces with robot

### Operation

All Rotary Indexing Tables and A-Axes are supplied with operating and mounting manuals. Interface information is also included. Observe all operation instructions of machine manufacturer when Rotary Indexing Tables, A-Axes and Rotating Spindles are connected with the machine control systems. Correct operation cannot be ensured and danger to personnel and machine cannot be excluded unless these operating instructions or information given in this catalogue are observed.

### Service and Maintenance

Since Rotary Indexing Tables and A-Axes are subject to chemical and physical influences, maintenance and service has to be performed with special care.

EDM current flow requires a good conductive connection (contact) to machine table. The conductivity of water (Wire EDM) and chlorides normally contained in water can influence the rust-resistant properties. Residues (varnishes, eroded particles etc.) from the electrical discharge process should be removed on a daily basis. Contact your local HIRSCHMANN dealer for recommended products to use.

### Technical Modifications

All products shown in this catalogue are subject to ongoing improvements and developments; we reserve the right for technical modifications without notice

### Quality according to EN9100

All HIRSCHMANN products are produced using state of the art production methods. They are subject to quality management system as per EN 9100 (aerospace industry standard) both during production and in the assembly stage.

### Warranty

We provide a 12 month warranty for all Rotary Indexing Tables and A-Axes, starting from the invoice date, and assuming correct use and maintenance as specified.

The warranty is restricted to replacement or repair, free of charge, of any defective parts. Claims arising from improper use or handling shall not be considered. Warranty claims must be submitted in writing and without delay.

■ Quality, Warranty	3
■ Introduction, Application	4
■ Precision, Control	5
■ Survey	6
■ Selection criteria	7
■ Rotary Indexing Tables	8
■ A-Axes H100R.NC.. series	10
■ A-Axes H150R.NC.. series	11
■ Rotating Spindle	12
■ Rotating /Positioning Spindle	13
■ Adjustable Clamping Element /Accessory	14



HIRSCHMANN GmbH

### Rotary Indexing Tables, A-Axes

Many erosion tasks cannot be solved efficiently without using a Rotary Indexing Table or an A-Axis, as for example wire cutting of carbide tipped tools. HIRSCHMANN Rotary Indexing Tables and A-Axes are especially designed for the field of erosion. They are completely sealed (IP68) and can therefore be used in the dielectric of sinking and wire EDM. The high-precision HIRSCHMANN Rotary Indexing Tables and A-Axes are based on many decades of experience and knowledge of the erosion problems.

### High Speed Rotating Spindles

The High Speed Rotating Spindles open new possibilities in spark erosion production. They enable erosion “turning” of the smallest parts with high surface quality not possible with conventional machining. An additional feature is the ability to accurately index the spindle as well as simultaneous processing with several other axes (turn while burn).

### Application

- **Medical technology (systems, instruments, implants)**
- **Aerospace (sensor measuring systems, micro-pumps, micro-valves, turbine blades)**
- **Automotive (electric plug connections (injection moulding))**
- **PCD/CBN processing**
- **Tool making (production of electrodes, direct structuring of workpieces, building of ejector pins)**
- **Machine building in general**



Controlled High Speed Rotating Spindle H8OR.MNC..

### Precision

HIRSCHMANN Rotary Indexing Tables and A-Axes are high-precision products. They are subject to strict quality inspections. A measurement report with the measured values is enclosed to every Rotary Indexing Table and A-Axis.

HIRSCHMANN Rotary Indexing Tables and A-Axes are equipped with precise Heidenhain direct measuring systems (encoders) and high-grade, backlash free drives. They offer the conditions for highest positioning accuracy and a high dynamic control.

The dividing accuracy depends on the quality of the measuring system (encoder). As standard we use measuring systems with a system accuracy of  $\pm 5''$  ( $\pm 10''$  or  $\pm 2,5''$  optionally). For a precise control a stiff and backlash free drive is essential.

### Control

HIRSCHMANN Rotary Indexing Tables and A-Axes can be controlled directly through the machine control. If this is not possible, they can be controlled by the HIRSCHMANN Control H1625xx.

For the easy and quick integration into the machine control, the Rotary Indexing Tables and A-Axes are equipped with drive components, measuring systems and plug connections which are adapted and adjusted to the machine control. The advantages of the integration are the possibility of simultaneous processing as well as programming in the machine control.

(We cannot guaranty our standard accuracies with some OEM encoders)

### **HIRSCHMANN Rotary Indexing Tables and A-Axes are compatible to the following EDMs:**

ACCUTEX, AGIE, BES, CHARMILLES, ELECTRONICA, EXERON, FANUC, JOEMARS, MAKINO, MITSUBISHI, ONA, OPS-INGERSOLL, SODICK etc.

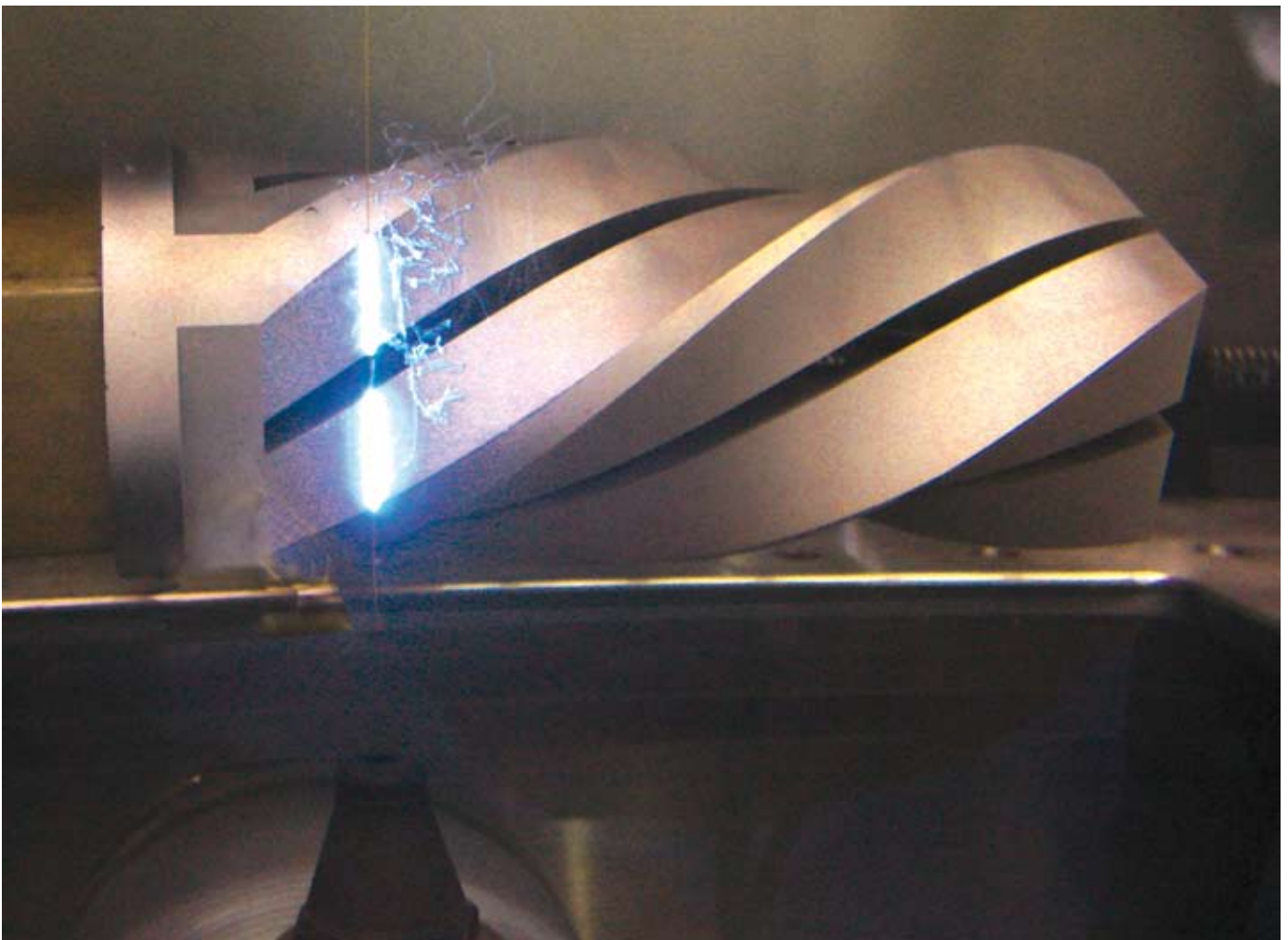

Simultaneous processing

**Common features**

- Precise direct measuring system for highest positioning accuracy (system accuracy optional  $\pm 10''$ ,  $\pm 5''$ ,  $\pm 2.5''$ )
- Stiff and backlash free drive for best dynamic behaviour during simultaneous processing (turn & burn)
- Compact, stainless design machined from solid blocks
- Low maintenance
- Completely sealed (IP68) – for the use in wire, sink and small hole EDM
- Size from  $\varnothing 80$  mm until  $\varnothing 800$  mm face-plate diameter

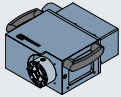
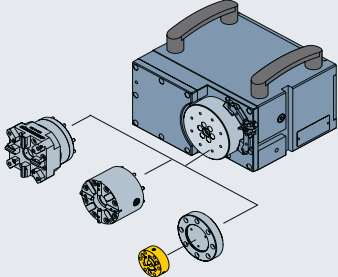
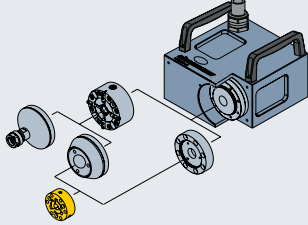
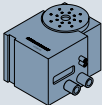
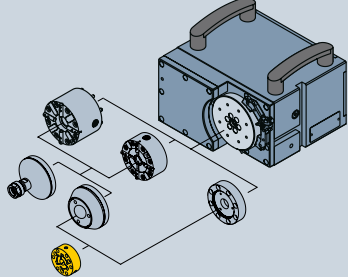
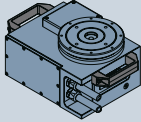
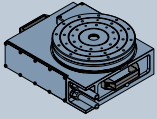
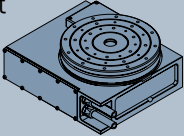
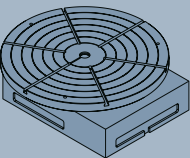
Rotary Indexing tables	A-Axes	High Speed Rotating Spindles
<p><b>H80R.NC</b> 25 kg loading weight Manual clamper</p> 	<p><b>H100R.NC,,, series</b> Face plate <math>\varnothing 100</math> mm 25 kg loading weight</p> <p><b>Options:</b></p> <ul style="list-style-type: none"> <li>- manual clamper</li> <li>- pneumatic clamper</li> <li>- clamper of other manufacturers</li> <li>- adjustable clamping element</li> <li>- customised devices</li> </ul> 	<p><b>H80R.MAC</b> Rotary speed 0 - 1500 min<sup>-1</sup></p> <p><b>Designs:</b></p> <ul style="list-style-type: none"> <li>- adjustable clamping element</li> <li>- manual clamper</li> <li>- clamper of other manufacturers</li> </ul> 
<p><b>H100R.NC</b> 50 kg loading weight Face plate <math>\varnothing 100</math> mm</p> 		<p><b>H80R.MNC.. (positionable)</b> Rotary speed max. 1000 min<sup>-1</sup> Indexing accuracy <math>\pm 5''</math></p> <p><b>Designs:</b></p> <ul style="list-style-type: none"> <li>- face-plate</li> <li>- adjustable clamping element</li> <li>- manual clamper</li> <li>- pneumatic clamper</li> <li>- clamper of other manufacturers</li> </ul> 
<p><b>H160R.NC</b> 100 kg loading weight Face plate <math>\varnothing 160</math> mm</p> 		
<p><b>H250R.NC</b> 250 kg loading weight Face plate <math>\varnothing 250</math> mm</p> 		
<p><b>H400R.NC</b> 450 kg loading weight Face plate <math>\varnothing 400</math> mm</p> 		
<p><b>H800R.NC</b> 2000 kg loading weight Face plate <math>\varnothing 800</math> mm</p> 		

Further designs on inquiry

## Selection criteria

### System accuracy

The positioning and indexing accuracy is dependent on:

- the measuring system (encoder)
- design and assembly of the axes
- controlling system

The influence of the encoder system accuracy is shown in the chart aside.

**Example:** In case of an encoder system accuracy of  $\pm 5''$  and a radius of 50 mm the position deviation (straight line) is max.  $\pm 0.0012$  mm.

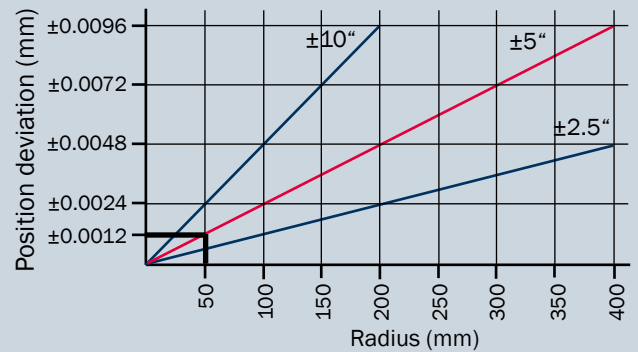

## Selection criteria

- 1. Size of workpiece and fixture** (weight, diameter, length)
- 2. Workpiece mounting** (face-plate, 3-jaw chuck, taper shank, clamping system)
- 3. Positioning accuracy** (alternatively  $\pm 10''$ ,  $\pm 5''$ ,  $\pm 2.5''$ )
- 4. High rotary speed** (for the production of dynamically balanced parts in rotation)
- 5. Available space** (size of machine table, travel, mounting possibility)
- 6. Control** (integrated to the machine or HIRSCHMANN control)

For detailed information contact HIRSCHMANN directly.

## Application form

### Rotary Indexing Table

- H 80R.NC
- H 100R.NC
- H 160R.NC
- H 250R.NC
- H 400R.NC
- H 800R.NC
- Special design

#### Encoder system accuracy

- $\pm 2.5''$
- $\pm 5''$  (standard)**
- $\pm 10''$
- Other: .....

#### Controlled by:

- HIRSCHMANN control
- Machine control  
Manufacturer: .....
- Type: .....

### A-Axis

#### Series H 100R.NC..

- Face plate  $\varnothing$  100 mm
- Manual clamper
- Pneumatic clamper
- Adjustable clamping element
- Other Type: .....

#### Series H 150R.NC..

- SK50 taper shaft collet
- HSK taper shaft collet (A,F): ....
- Face plate  $\varnothing$  150 mm
- Manual clamper
- Pneumatic clamper
- Adjustable clamping element
- 3-jaw chuck
- Other Type: .....

#### Encoder system accuracy

- $\pm 2.5''$
- $\pm 5''$  (standard)**
- $\pm 10''$
- Other: .....

#### Controlled by:

- HIRSCHMANN control
- Machine control  
Manufacturer: .....
- Type: .....

### Rotating spindle

#### Series H 80R.MAC..

- Manual clamper H 6.16R
- Manual clamper H 8.16R
- Adjustable clamping element
- Other Type: .....

#### Controlled by:

- HIRSCHMANN-Steuerung
- Other .....

#### Serie H 80R.MNC..

- Face plate  $\varnothing$  80 mm
- Manual clamper H 6.16R
- Manual clamper H 8.16R
- Pneumatic clamper
- Adjustable clamping element
- Other Type: .....

#### Encoder system accuracy

- $\pm 2.5''$
- $\pm 5''$  (Standard)**
- $\pm 10''$
- Other: .....

#### Controlled by:

- HIRSCHMANN control
- Machine control  
Manufacturer: .....
- Type: .....

## Rotary Indexing Tables

All HIRSCHMANN Rotary Indexing Tables are equipped using direct measuring system with a system accuracy of  $\pm 5''$  (except the H 100R.NC) and an electromagnetic or pneumatic braking. DC drives are standard with AC drives offered as an option.

### Common characteristics

- Direct measuring system
- Backlash free drive
- For horizontal and vertical use (except H80R.NC)
- DC drive, (available also with AC drive)
- Stainless steel
- Completely sealed - IP68



### H80R.NC Rotary Indexing Axis (stainless steel)

with manual clamper H 6.16R or H 8.16R for pallets and holders of the HIRSCHMANN Fixturing System 5000 (other systems on request). Horizontal use only.

Dimensions (W/D/H)	230/252/130 mm (9/9.9/5.12")
Min. indexing step	0.001° / 3,6"
Indexing accuracy (standard encoder)	≤ ±5"
Repetitive accuracy	≤ ±3"
Loading weight	max. 25 kg (55.125 lbs)
Direct measuring system accuracy	±10, ±5 or ±2,5"
Drive	DC motor
Brake holding force (electromagnetic)	20 Nm
Speed max.	20 min <sup>-1</sup>
Weight approx.	35 kg (77.175 lbs)



### H100R.NC Rotary Indexing Table (stainless steel)

Face plate (mounting surface) Ø 100 mm, for horizontal and vertical use.

Dimensions (W/D/H)	188/125/135 mm (7.41/4.93/5.32")
Min. indexing step	0.001° / 3,6"
Indexing accuracy	≤ ±25"
Repetitive accuracy	≤ ±10"
Loading weight	max. 50 kg (110.25 lbs)
Direct measuring system	ERN 480
Drive	DC motor
Brake holding force (pneumatic)	25 Nm
Speed	max. 10 min <sup>-1</sup>
Weight approx.	15 kg (40 lbs)



### H160R.NC Rotary Indexing Table (stainless steel)

with face plate (mounting surface) Ø 160 mm, for horizontal and vertical use.

Dimensions (W/D/H)	265/203/148 mm (10.5/8/5.8")
Min. indexing step	0.001° / 3,6"
Indexing accuracy (standard encoder)	≤ ±5"
Repetitive accuracy	≤ ±3"
Loading weight	max. 100 kg (220.5 lbs)
Direct measuring system accuracy	±10, ±5 or ±2,5"
Drive	DC motor
Brake holding force (electromagnetic)	40 Nm
Speed	max. 7 min <sup>-1</sup>
Weight approx.	40 kg (88.2 lbs)



### H250R.NC Rotary Indexing Table (stainless steel)

with face plate (mounting surface)  $\varnothing$  250 mm, for horizontal and vertical use.

Dimensions (W/D/H)	340/290/135 mm (13.4/11.4/5.3")
Indexing accuracy (standard encoder)	$\leq \pm 5''$
Repetitive accuracy	$\leq \pm 3''$
Loading weight	max. 250 kg (551 lbs)
Direct measuring system accuracy	$\pm 10, \pm 5$ or $\pm 2,5''$
Drive	DC motor
Brake holding force (electromagnetic)	40 Nm
Speed	max. 5 min <sup>-1</sup>
Weight approx.	60 kg (130 lbs)



### H400.NC Rotary Indexing Table (steel)

### H400R.NC Rotary Indexing Table (stainless steel)

similar to H 250R,NC but with face plate  $\varnothing$  400 mm

Dimensions (W/D/H)	490/410/175 mm (19.3/16.2/6.9")
Loading weight	max. 450 kg (992 lbs)
Weight	approx. 200 kg (440 lbs)
Brake holding force (electromagnetic)	40 Nm

### H800.NC Rotary Indexing Table (steel)

### H800R.NC Rotary Indexing Table (stainless steel)

similar to H 250R,NC with face plate  $\varnothing$  800 mm

Dimensions (W/D/H)	820/800/250 mm (32.3/31.5/9.9")
Loading weight	max. 2000 kg (4410 lbs)
Weight	approx. 620 kg (1367 lbs)
Brake holding force (electromagnetic)	350 Nm



### H1625.DC CNC Control

Positioning control for H 80R.NC, H 160R.NC , H 250R.NC.

Dimensions (W/D/H)	approx. 520/420/230 mm (19.3/15.8/9")
Power supply	115/230 V 50/60 Hz
Weight	approx. 12 kg (25 lbs)

### H1625.DC1 CNC Control

similar to H 1625.DC, for H 400.NC, H 400R.NC

### H1625.DC3 CNC Control

similar to H 1625.DC, for H 100R.NC

### H1625.DC4 CNC Control

similar to H 1625.DC, for H 800.NC

## General

The stainless steel A-Axes of the series H100R.NCx are equipped with a face-plate diameter 100 mm. Optionally, the A-Axes can be equipped with a manual or pneumatic clumper, an adjustable clamping element or with customised devices. The encoder system accuracy is  $\pm 5''$  seconds as standard (see equipment possibilities). Optionally it can be delivered with an integrated air supply for pneumatic clumpers or customised devices. The axes can be integrated directly to the machine control for indexing and simultaneous multi-axes erosion (turn while burn). Or, indexing only with the HIRSCHMANN H1625.AC1 control.



H100R.NCx000 with face-plate

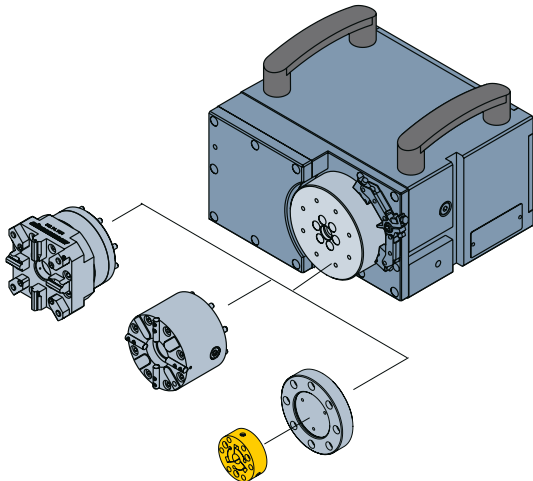

## H100R.NC... A-Axis

with face-plate  $\varnothing 100$  mm, centering seat 15<sup>H7</sup> and eight fastening screw threads M6, for horizontal and vertical use.

Dimensions (W/D/H)	230/215/130 mm (9.1/8.5/5.12")
Indexing accuracy (standard encoder)	$\leq \pm 5''$
Smallest indexing step (standard encoder)	0.0005° (1.8")
Radial run-out	$\leq 0,005$ mm
Axial run-out	$\leq 0,005$ mm
Moment of inertia of the workpieces	$\leq 375$ kgcm <sup>2</sup>
Weight	approx. 30 kg
Speed	max. 20 min <sup>-1</sup>
Protection class	IP68
Max. weight of workpiece	horizontal use: 15 kg vertical use: 25 kg

## Options

### Workpiece mounting\*

- manual HIRSCHMANN clumper H 6.16R, H 8.16R
- pneumatic HIRSCHMANN clumper H 6.11.10R, H 8.11.10R
- manual and pneumatic clumpers of other manufacturers
- customised devices
- integrated air supply for pneumatic clumpers and devices

### Encoder system accuracy \*

- $\pm 10''$
- **$\pm 5''$  (standard)**
- $\pm 2,5''$

### Electrical equipment\*

For the adaption to the machine control the A-Axes can be equipped with different drives and connectors.

\* Please specify when ordering

## H1625.AC1 CNC control

for A-Axis series H100R.NC.. and H150R.NC..

Dimensions (W/D/H)	approx. 520/420/230 mm
Power supply	115/230 V 50/60 Hz
Power input	max. 400VA
Weight	approx. 12 kg (25 lbs)

### General

The stainless steel A-Axes of the series H 150R.NC are equipped as standard with a pneumatic SK50, CAT50 or HSK63 machine taper chuck. Optionally, the A-Axes can be equipped with a face-plate  $\varnothing 150$  mm, a manual or pneumatic clammer, an adjustable clamping element or with customised devices. The drive components are matched to the machine control and the accuracies are dependent on the measuring system (encoder).



H 150R.NC with SK50 taper chuck



H 150R.NC with HSK63 taper chuck

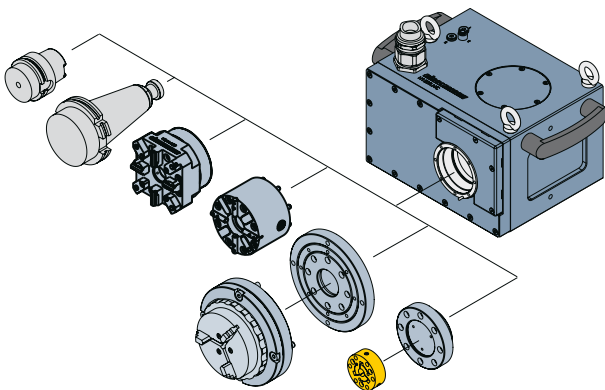

### H150R.NC.. A-Axis

alternatively with SK50, CAT50 or HSK63 (form A or F) taper chuck. For horizontal and vertical use.

Dimensions (W/D/H)	approx. 265/215/160 mm (10.43/8.47/6.3")
Indexing accuracy (standard encoder)	$\leq \pm 5''$
Repetitive accuracy (standard encoder)	$\leq \pm 3''$
Smallest indexing step (standard encoder)	0.0005° (1.8")
Radial run-out	$\leq 0,005$ mm
Max. weight of workpiece	50 kg
Speed	max. 20 min <sup>-1</sup>
Weight	approx. 45 kg
Erosion current	max. 50 A
Protection class	IP68

### Options

#### Workpiece mounting\*

- manual HIRSCHMANN clammer H6.16R, H8.16R
- pneumatic HIRSCHMANN clammer H6.11.10R, H8.11.10R
- manual and pneumatic clammers of other manufacturers
- face-plate  $\varnothing 150$  mm
- jaw chuck
- customised devices
- integrated air supply for pneumatic clammers and devices

#### Encoder system accuracy \*

- $\pm 10''$
- $\pm 5''$  (standard)
- $\pm 2,5''$

#### Electrical equipment\*

For the adaption to the machine control the A-Axes can be equipped with different drives and connectors.

\* Please specify when requesting a quotation

## Advancing into new technology

High speed rotary spindles open new possibilities in spark erosion production. They enable erosion “turning” of the smallest parts with high surface quality (Ra 0.1 mm and better) not possible with conventional machining. (Lathes and grinding machines) This is now possible with HIRSCHMANN high speed rotary spindles.

### Characteristics:

- Alternative to hard turning or precision grinding of dynamically balanced parts with highest surface quality
- Economic production of parts with minimal structures, as well as micro electrodes made of stainless steel, hard metal or nonferrous metal and even conductive ceramics.

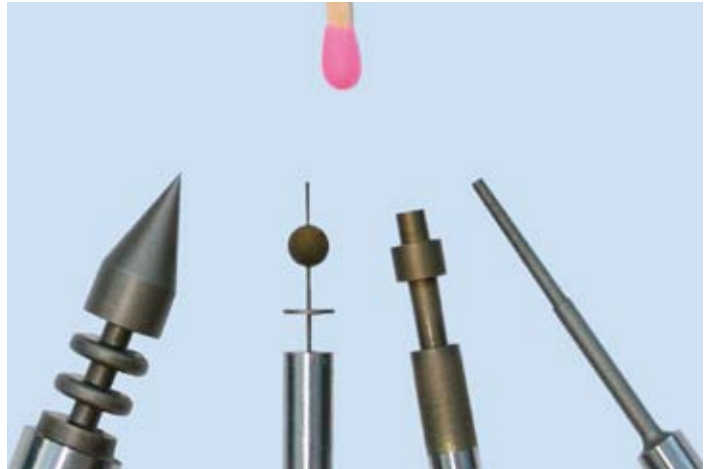

### H80R.MAC Rotating Spindle

with manual clammer H 8.16R (for clamping journal H 5.611R). Rust-proofed, maintenance free AC-Drive.

Dimensions (WxDxH) 190/191/98 mm (7.5/7.52/3.9")  
 Speed 0-1500 min<sup>-1</sup>  
 Axial accuracy ≤ 0,003 mm (0.00012")  
 Weight approx. 20 kg



### H80R.MAC.6 Rotating Spindle

Similar to H 80R.MAC but with manual clammer H 6.16R (for clamping journal H 6.611R).



### H80R.MAC.44 Rotating Spindle

Similar to H 80R.MAC but equipped with adapter disc for mounting the Adjustable Clamping Elements H 5.83.46R-xx. With an integrated bore for long workpieces Ø 18 mm, 100 mm deep.

### H1680.AC4 Speed Control Unit

for speed control of the H 80R.MAC.. Rotating Spindles.  
 Dimensions (W/D/H) 270/330/320 mm  
 Mains voltage 230V / 50/60 Hz  
 Power input max. 500 VA

### H1680.AC411 Speed Control Unit

Same as H 1680.AC4 but including a interface for automatic start and stop of the spindle via the machine control (M-code).



Micro pin structure in hard metal, length 1 mm

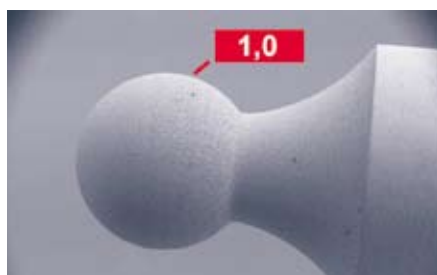

Stainless steel piston for micro pump, accuracy of the ball profile 1 - 2 µm



Stainless steel needle for medical technics, Ra 0.2 - 0.25 µm

## High Speed Rotating/Positioning Spindle H80R.MNC

The H80R.MNC high speed rotating and indexing spindle allows complete production of complex parts in the same set-up. Depending on the machine control the axes can be integrated directly to the machine control for indexing, spinning or simultaneous multi-axis erosion (turn while burn). If direct integration is not possible, high speed rotation and indexing can be controlled through the HIRSCHMANN H1625.AC3 control with communication to the machine via M-code.



Rotating/Positioning Spindle with clamber

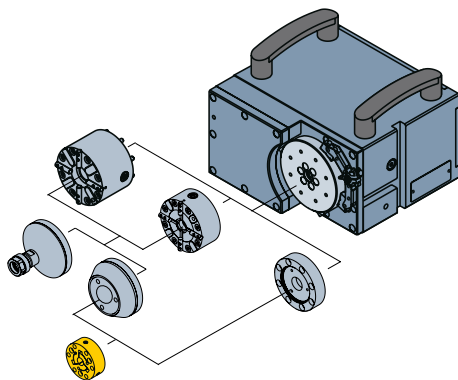

### H80R.MNC.. Rotating/Positioning Spindle

Rust-proof, long-life AC drive

Dimensions (W/D/H)	approx. 265/212/120 mm (10.43/8.35/4.72")
Speed	0-1000 min <sup>-1</sup>
Indexing accuracy (direct measuring system)	± 5"
Axial accuracy	≤ 0,003 mm
Loading weight	max. 30 kg
Weight	approx. 31 kg

### Design versions

- face-plate Ø 80 mm
- manual clamber H6.16R, H8.16R
- pneumatic clamber H6.11.10R, H8.11.10R
- support for adjustable clamping element H5.83.46R-xx
- clamber of other manufacturers



### H1625.AC3 Control

for Rotating/Positioning Spindle H80R.MNC..

Dimensions (W/D/H)	520/420/230 mm (19.3/15.8/9")
Power supply	230 V 50/60 Hz
Power input	max. 1000 VA
Weight	approx. 10 kg (22.05 lbs)



### Adjustable Clamping Element – erosion grinding with high precision

High accuracy requires a precise concentricity. With the HIRSCHMANN Adjustable Clamping Element the concentricity can be quickly and easily adjusted to  $\leq 0,001$  mm.

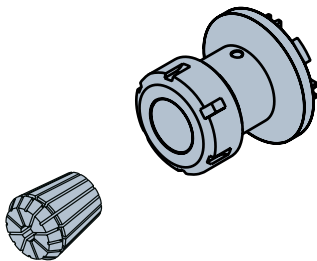
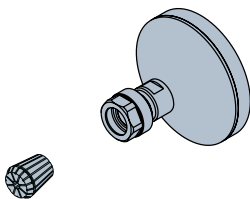
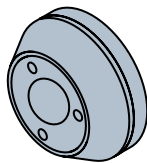

#### H5.83.46R-xx Adjustable Clamping Element (Brass)

for the precise adjustment of the workpiece concentricity. The Adjustable Clamping Elements are mounted to the Clamping Element Holder H5.83.45R or directly to the Rotating Spindles resp. A-Axes equipped with Adjustable Clamping Elements.

Concentricity adjustable to  $< 0.001$  mm  
Clamping range (xx) from  $\varnothing 1$  mm until  $\varnothing 20$  mm  
(When ordering, please state the exact clamping diameter (xx))

#### H5.83.45R Clamping Element Holder (stainless)

for mounting the Adjustable Clamping Elements H5.83.46R-xx in the Rotating Spindles, Axes and Presetting Spindles with HIRSCHMANN clampers.

Please order Clamping Journal H5.611R resp. H6.611R separately!

#### H5.83.40R.MAC Collet Holder (stainless)

Clamping nut nickel plated. For collet H50.41.

Concentricity (without collet)  $0,005$  mm  
Please order Clamping Journal H5.611R resp. H6.611R separately!

#### H50.41 Collet ER/ESX 16 (non stainless)

Clamping range infinitely variable from  $\varnothing 0.5 - \varnothing 10$  mm.  
Collet size from  $\varnothing 1 - \varnothing 10$  mm, in 1 mm increments.  
Radial deviation until  $\varnothing 5$  mm = 0.01, from  $\varnothing 6$  mm = 0.02 mm  
Stainless edition on request.

#### H5.83.50R Collet Holder (stainless)

Clamping nut nickel plated. For collet H5.50.51 (ER40).  
Clamping range  $\varnothing 3 - \varnothing 26$  mm.

Concentricity (without collet)  $0,01$  mm  
Weight  $1,1$  kg  
Please order Clamping Journal H5.611R resp. H6.611R separately!

#### H5.50.51 Collet ER/ESX 40 (non stainless)

Clamping range infinitely variable from  $\varnothing 3 - \varnothing 26$  mm.  
Collet size from  $\varnothing 4 - \varnothing 26$  mm, in 1 mm increments.  
Radial deviation until  $\varnothing 6$  mm = 0.015, from  $\varnothing 7$  mm = 0.02 mm



H80R.MAC with Holder H5.83.45R and Adjustable Clamping Element H5.83.46R



H80R.MAC with Collet Holder H5.83.40R



H80R.MAC.44 with Adjustable Clamping Element H5.83.46R

### Presetting workpiece concentricity

The Presetting Spindle allows the adjustment of concentricity outside the machine tool simultaneous to machine operation. After alignment the Clamping Element or collet holder holding the workpiece can be accurately loaded manually by hand or automatically with a robot into the Rotating Indexing Spindle or A-Axes within seconds.

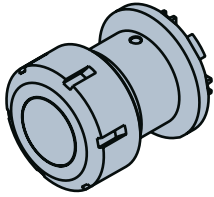

#### H5.83.70R Collet Holder (stainless)

Clamping nut nickel plated. For collet ER50 (clamping range  $\varnothing 3 - \varnothing 34$  mm).

Concentricity (without collet)

0,01 mm

Weight

1.6 kg

Please order Clamping Journal H5.611R resp. H6.611R separately!



H5.611R +  
H5.611.1R



H6.611R

#### H5.611R Clamping Journal and

#### H5.611.1R Centering Bush (stainless)

to use the holders H5.83.45R, H5.83.40R.MAC, H5.83.50R and H5.83.70R in the clamper H8.16R.

#### H6.611R Clamping Journal (stainless)

to use the holders H5.83.45R, H5.83.40R.MAC, H5.83.50R and H5.83.70R in the clamper H6.16R.

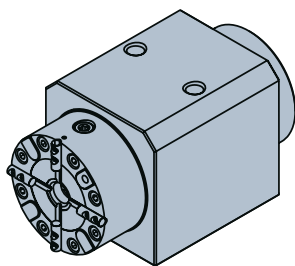

#### H5.83.60R Presetting Spindle (Clamper H8.16R)

to preset the concentricity of the parts which are clamped in the Adjustable Clamping Element H5.83.46R and mounted to the Clamping Element Holder H5.83.45R.

Concentricity

$\leq 0,002$  mm

#### H6.83.60R Presetting Spindle (Clamper H6.16R)

similar to H5.83.60R but with Clamper H6.16R

Presetting Work Stations on request.



Presetting with Presetting Spindle and Adjustable Clamping Element



Adjustment of radial run-out with Adjustable Clamping Element H5.83.46R..



Adjustment of axial run-out with Adjustable Clamping Element H5.83.46R..

**ROTARY TABLES and A-AXES**  
for Wire and Sinking EDM



## PRODUCT OVERVIEW

**FIXTURING SYSTEM 4000**  
for Wire EDM

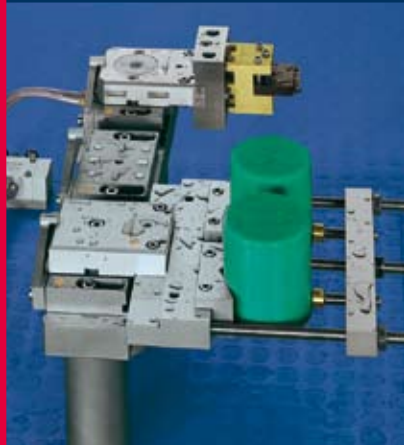

**FIXTURING SYSTEM 5000**  
for Sinking EDM

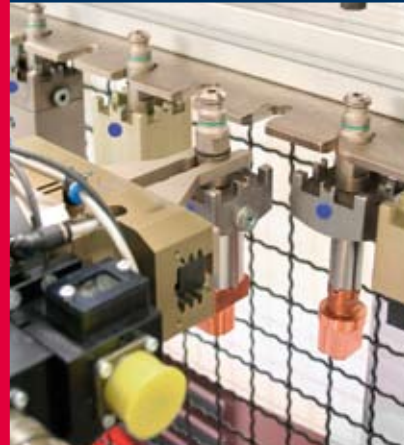

**PALLETIZING SYSTEM 8000**  
for Machine Tools



**FIXTURING SYSTEM 9000**  
Modular Zero-Point Fixturing



### Representatives, consultants and distributors in:

Australia · Austria  
Belgium · Brazil · Bulgaria  
Canada · China · Croatia  
Czech Republic  
Denmark  
Finland · France  
Great Britain  
Hong Kong · Hungary  
India · Indonesia · Israel · Italy  
Japan · Korea · Malaysia  
Netherlands · Norway · New Zealand  
Philippines · Poland · Portugal  
Singapore · Slovakia · Slovenia  
Spain · Sweden · Switzerland  
Taiwan · Thailand · Turkey  
United States

**HEAVY-DUTY ROD ENDS and  
SPHERICAL BEARINGS**



Catalogues upon request