

Im Lieferumfang
 Palette enthalten
 (Spannzapfen H6.611R)

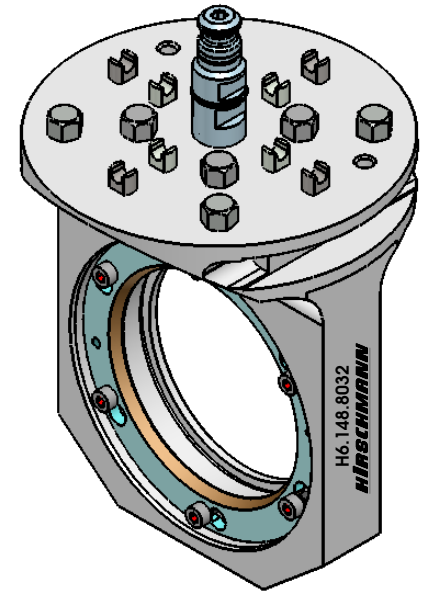

Spannvorrichtung für
 Werkstück Gr. 14

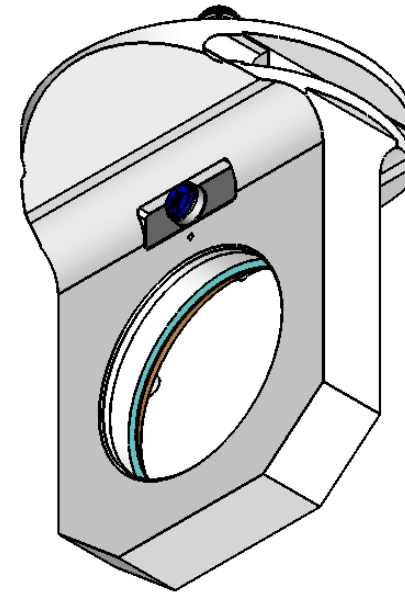
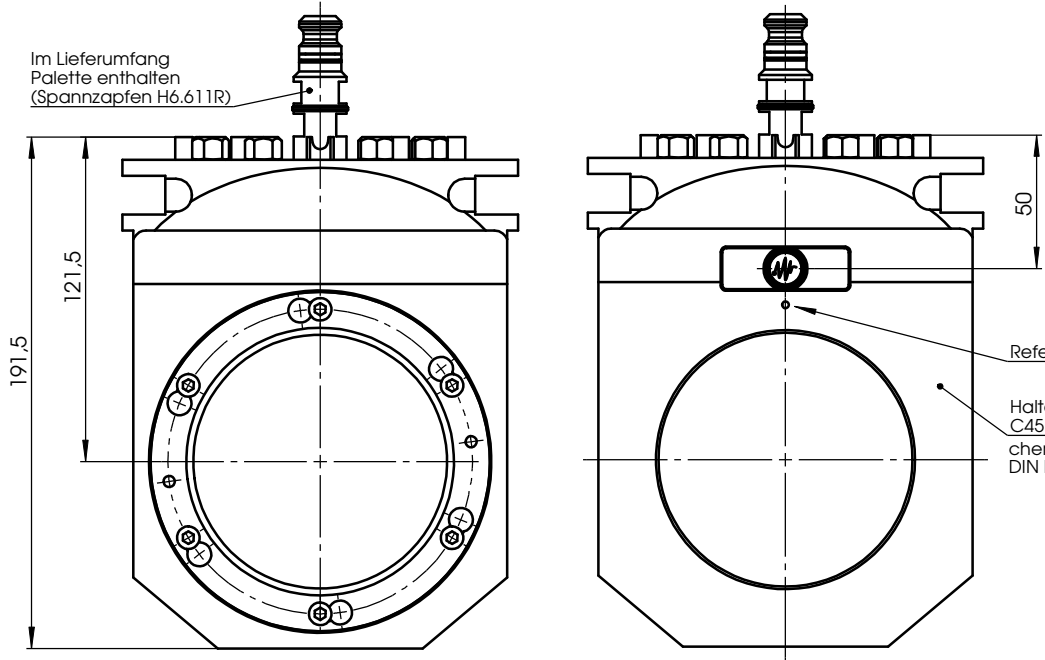
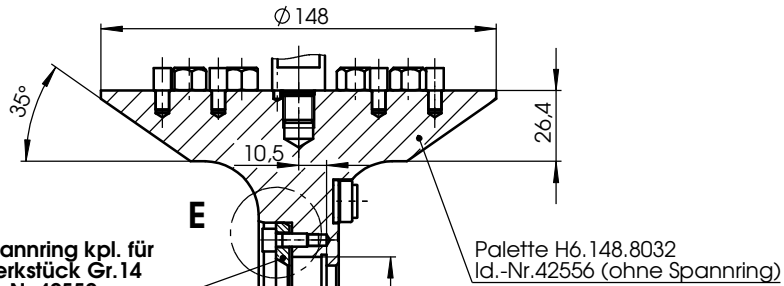

Spannring kpl. für
 Werkstück Gr. 14
 Id.-Nr.42552

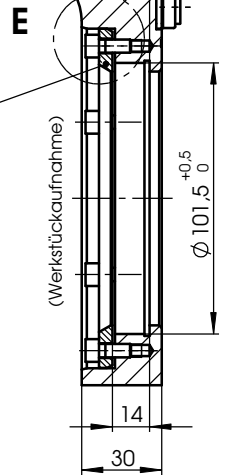

E (1 : 1)

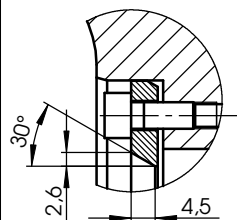

Spannvorrichtung für
 Werkstück Gr. 18

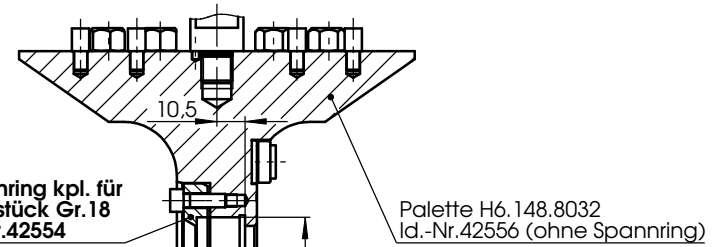

Spannring kpl. für
 Werkstück Gr. 18
 Id.-Nr.42554

