

mit Dichtring H6.10.105
für Palette H6.105

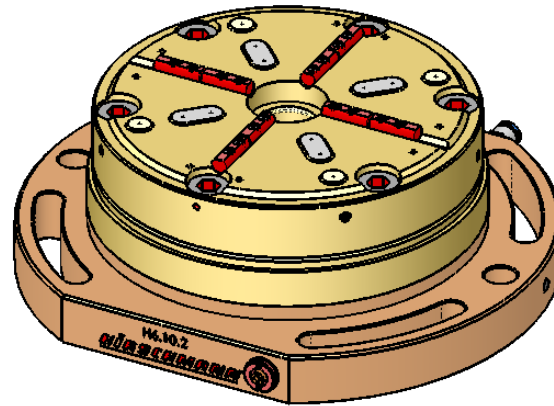

mit Dichtring H6.10.148
für Palette H6.148

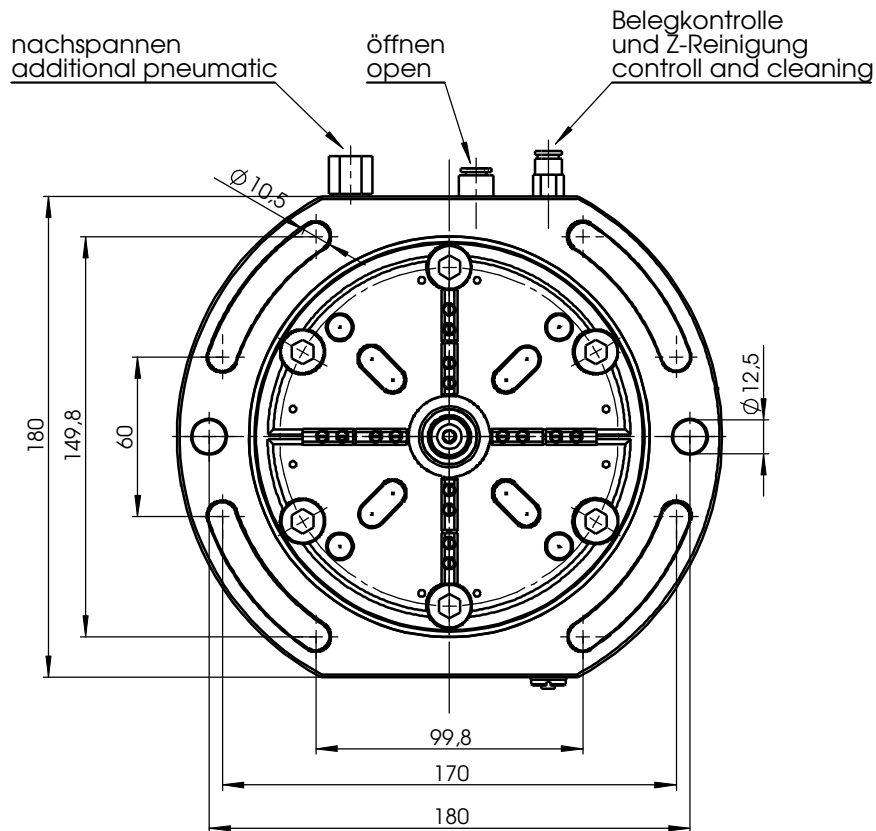
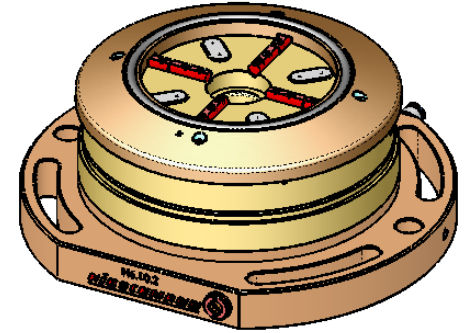
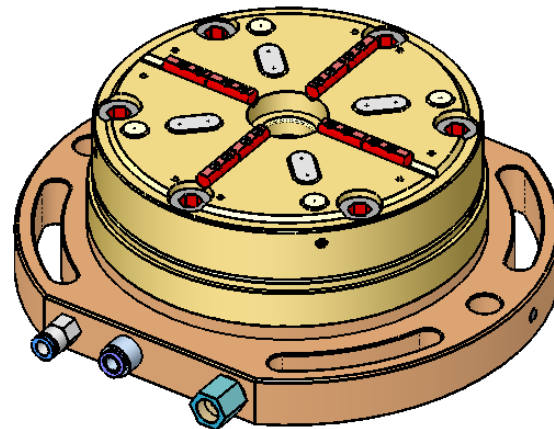
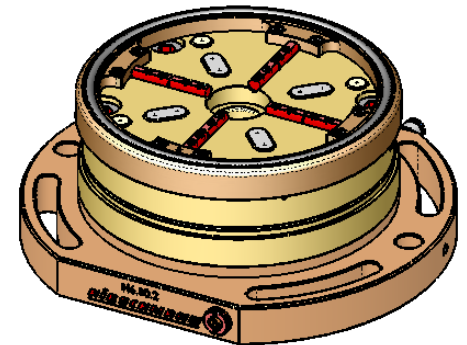

Technische Daten: Technical data:	
Positioniergenauigkeit Positioning accuracy	: 0,002 mm
Spannkraft des Futters mit Federn Clamping force with spring	: 10.000 N
Spannkraft mit pneum. Nachspannen Clamping force with comp. air	: 18.000 N
öffnen / open	: 6 bar